

# Installation Manual

## aSENSE mIII Duct

CO<sub>2</sub> / CO sensor with built-in  
General purpose controller

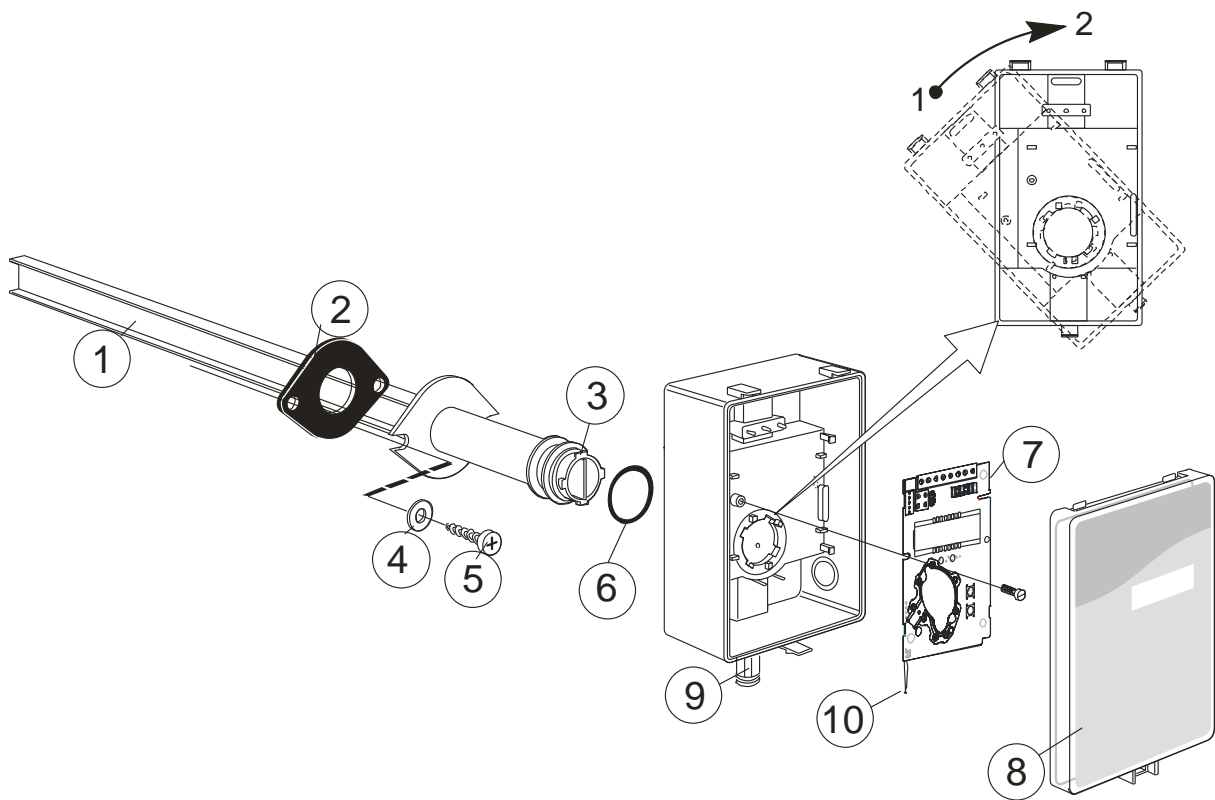

- |                            |  |
|----------------------------|--|
| 1 Sampling probe           | 6 O-ring 29,2x3,53                                       |
| 2 Sealing gasket           | 7 PCB (Factory supplied mounted in box)                  |
| 3 Largest locking nob      | 8 Snap-in lid  |
| 4 2 washers (Not included) | 9 PG9 cable entry bushing                                |
| 5 2 screws (Not included)  | 10 Temperature sensor (to be put into the sampling tube) |

Fig. 1.

■ ■ ■ ■  
**Senseair**

■ ■ ■ ■  
an Asahi Kasei company

## Mounting of aSENSE mIII Duct on to the duct.

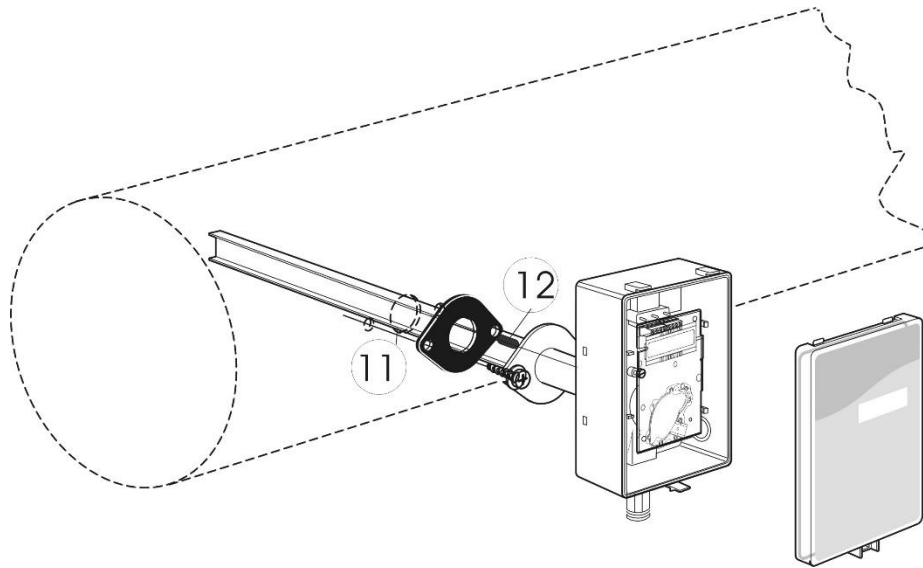

11 Hole with 25 mm diameter

12 Temperature sensor with 110 mm cable mounted in the sampling probe

Fig. 2.

## Mounting Instruction

Since there might be a substantial pressure difference in duct mounting applications, it is essential to avoid ambient air from suction into the duct mounting box. For correct function it is indispensable that the sealing of the box cover, the cable entry bushings, the cable feed through and the duct entrance are absolutely tight. The duct entrance may need extra sealing paste in order to prevent leakage. The PCB must be handled carefully and protected from electrostatic discharge.

1) **Electrical cable entry:** The box has a factory mounted cable entry bushing in dimension PG9. Never feed more than one cable through each cable entry bushing, or else gas might leak through!

2) **Mounting the tube:** Drill a hole (10) with 25 mm diameter (or 1 inch) for the sampling probe and two holes with 4 mm diameter for the screws (5) into the air duct and mount the tube (1) with the gasket (2). The sampling probe should be mounted with the largest locking knob on top. The unit can be mounted with the air coming from the left or right.

3) **Attaching the sensor box** is made to the sampling probe by a snap-in bayonet fitting. First, carefully stick the temperature probe (11) into the sampling probe. (1). Orient the box onto the sampling probe so that the box upside is on the same side as the largest locking knob (3). When the probe is fitted into the notches of the box, then turn the box clockwise until stop (see Figure 1). Position 1 indicates *open* where the box can be removed from the sampling probe. In position 2 the box is locked to the probe.

If for some reason the PCB must be removed, it must be handled carefully and protected from electrostatic discharge! Normally, removing the PCB is not required.

## Electrical connections

The power supply has to be connected to  and .  is considered as system ground. Unless different transformers are used, special precautions need to be taken.

### NOTE:

The signal ground *is not* galvanically separated from the aSENSE mIII power supply!

The same ground reference has to be used for the aSENSE mIII unit and for the control system!





Connection Terminal	Function	Electrical Data	Remarks
 	Power (+)	24 V AC/DC+ (+-20%), 3W	2 W without output load See note 1
	Power ground (-)	24 V AC/DC-	
Out(1)	Analogue Output 1 (+)	0 – 10 V DC or 0 – 20 mA, 2 – 10 V DC or 4 – 20 mA,	According to positions of Out(1) jumper and start point selection. See note 2
Out(2)	Analogue Output 2 (+)	Same as Output 1	According to positions of Out(2) jumper and start point selection. See note 2
5	Signal Ground (-)	Connected to  via PTC fuse	See note 1
6	Normally closed relay	Contact free relay minimum load 1 mA/5 V rated load 0.5A/125 V AC; 1 A/24 V DC	Triggered by register Out(3)
7	Open at alarm situations and power loss		
8	Analogue Output 4 (+)	0-10 VDC	According to positions of Out(4). See note 2 & 3!
Out(4)	or Open Collector	Max 0.5 A, 55 V DC / 40VAC (half-wave rectifier protection)	
DI1	Digital Input 1	Closed contact current 1 mA Open contact voltage max 5 V	<b>Do not apply any voltage on this input!</b>

Table I. Electrical terminal connections for aSENSE mIII

**Note 1:** The ground terminal is used as negative power supply DC input or AC phase ground  (halfwave rectifier). The signal ground M, protected by a PTC resistor, is the same as power ground G0 (permitting a "3-wire" configuration). A single transformer may be used for the entire system.

**Note 2:** aSENSE mIII can deliver both a voltage or a current loop for Out(1)/Out(2). For Out(4) a voltage output or an open collector output is selected with jumper Out(4). To change between voltage and current output mode the hardware jumpers are used. There is one jumper for Out(1) and one for Out(2), so that one output can be a voltage output and the other a current output. Both, voltage output and current output, can have start points 0% (0 – 10 VDC or 0 – 20 mA) or 20% (2 – 10 V DC or 4 – 20 mA) selected from PC software. See the user manual.

**Note 3:** Current of Open Collector is internally returned to  terminal.

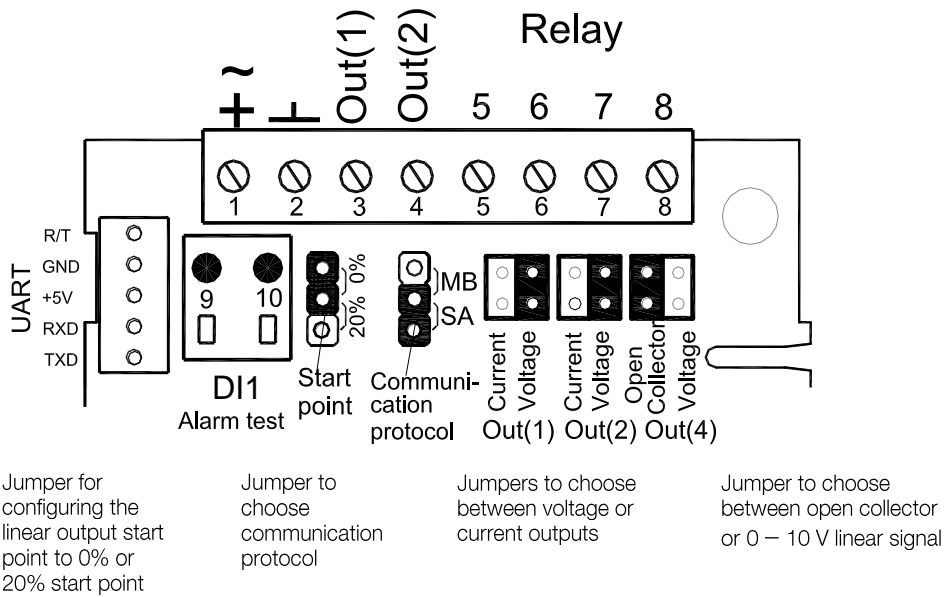

Fig. 3. Terminals and jumpers on aSENSE mIII Duct. The darker positions are default settings.

Numbers in figure 3	Label or marking	Function
3	Out(1)	CO-transmitter 0-100 ppm CO
4	Out(2)	CO <sub>2</sub> -transmitter 0-100 ppm CO <sub>2</sub>
6, 7	Out(3)	Gas alarm CO >35 ppm or CO <sub>2</sub> >1500 ppm
8	Out(4)	Error detected or gas alarm
9, 10	DI 1	Extra terminal. Alarm test function (N.O.)

If more holes are needed the box has several drill markings for holes in two dimensions, PG7 and PG9. Then fasten the cable entry bushing and seal properly. Never feed more than one cable through each cable entry bushing, or else gas might leak through!

The PCB can be removed during the making of holes. The PCB must be handled carefully and protected from electrostatic discharge!

## Start-up of the aSENSE mIII Duct

Connect the power directly after mounting. The unit works best if the sensor is continuously powered. The analogue outputs do not need to be connected before use. An internal delay function prevents the alarm functions of the relay and OUT4 output during 2 minutes after power up. After short power failures the CO measurements need this power up time to stabilize. The alarm outputs may be tested after the 2 minutes delay by shorting the switch DI1. After long power failures the sensor may need several days to restore the measuring functions.

### NOTE:

The CO probe gives incorrect readings near some chemicals, e.g. silicone. This makes certain environments unsuitable for the sensor.