

Product Specification

aSENSE MIII (Duct) (Disp)

CO₂ / CO sensor with built-in general purpose controller



aSENSE MIII Disp



aSENSE MIII Duct Disp

General

The IAQ-sensor in a housing product aSENSE MIII is used to measure indoor air carbon dioxide and carbon monoxide concentrations. It is a very flexible controller with programmable outputs for both relay- and linear control of e.g. mixed air dampers, humidifier and fans. The measured values are shown on the display.

The unit can alternatively be connected to common VAV (Variable Air Volume) controllers, or Direct Digital Control (DDC). The linear output functions are pre-programmed. All functions can be modified from a PC with the software UIP (version 4.3 or higher) and Senseair's standard communication cable for PC.

Key technical specification

Item	aSENSE MIII (Duct) (Disp) specification
Measured gases	Carbon dioxide (CO ₂) and Carbon monoxide (CO)
Operating Principles	For carbon dioxide: Non-dispersive infrared (NDIR) waveguide technology For carbon monoxide: Fuel type electrochemical gas sensor with temperature compensation
OUT1 CO	0–10VDC, programmable output pre-programmed 0–100ppm CO
OUT2 CO ₂	0–10VDC, programmable output pre-programmed 0–2000ppm CO ₂
OUT3	Relay pre-programmed with two minutes delay after start: ON < 30ppm CO AND <1400ppm CO ₂ The green LED is lit OFF > 35ppm CO AND > 1500ppm CO ₂ The relay is open in alarm situations and at power loss. The red LED is lit and the green LED is not lit.
OUT4	Open collector, error status with two minutes delay after start: Open: No error detected AND normal gas concentrations Closed: Error detected OR high gas concentrations The red LED is lit if an error OR high gas concentrations are detected. If an error is detected also the yellow LED is lit. If an error is detected and the gas concentrations are normal all three LEDs are lit.
DI1	Switch with delay timer for test function. Default normally open
Accuracy CO	±10ppm <i>The CO probe also responds to some other chemicals than CO, e.g. silicon. Some non-common operation environments therefore may not be applicable for this product!</i>
Accuracy CO ₂	±30ppm ± 3% of measured value ¹
Response time (T _{1/e}) CO	< 3 min. diffusion time
Response time (T _{1/e}) CO ₂	< 3 min. diffusion time
Pressure Dependence	+1,6% reading per kPa deviation from normal pressure, 100kPa
Maintenance push buttons	Push button menus are available for configuration of outputs e.g. set points
Accuracy Temp	±1°C
Operating Temperature Range	0–50°C
Operating Humidity Range	5–85%RH (non-condensing)
Operating environment	Residential, commercial ¹
Storage temperature	-40–70°C (display models: -20–50°C)
Dimensions wall mounted (mm) in industrial housing	152 x 85 x 47
Dimensions duct mounted (mm)	152x85x47 (Probe length: 245mm)
Power supply	24VDC or 24VAC (50–60Hz) ±20%, half-wave rectifier input

Power consumption	< 3W average
Life expectancy	> 5 years ^{2,3}
Yearly drift	< ±150ppm @1000ppm ⁴ < ±100ppm @0ppm ⁴
Serial communication	UART (Senseair protocol standard)
Maintenance	No maintenance required as Auto Baseline Correction (ABC), is used. ⁵

Table 1. Key technical specification for the aSENSE MIII

Note 1: Accuracy is specified over operating temperature range. Specification is referenced to certified calibration mixtures. Uncertainty of calibration gas mixtures (±2% currently) is to be added to the specified accuracy for absolute measurements.
 Note 2: Is limited by the CO probe
 Note 3: Repeatability is included. Uncertainty of calibration gases (±2% currently) is added to the specified accuracy.
 Note 4: Yearly drift of unpowered sensor is not defined
 Note 5: In normal IAQ applications, accuracy is defined after minimum three (3) ABC periods of continuous operation with ABC.

aSENSE MIII is delivered pre-programmed (see description below). With the free software UIP5 (or higher versions) and Senseair's standard communication cable for PC, the user can adjust the product to his/hers application by e.g.

- changing the measurement ranges of the linear outputs
- modify the set points of the alarm outputs
- invert outputs
- reconfigure the functions
- reconfigure the logic that controls the outputs.

Internal CO and CO₂ recorder samples data continuously every 20 minutes. After 13 days and 8 hours the storage memory is full and the oldest data are eventually overwritten one by one. The data storage is secured every four hours. In case of power failure the sampled data of the latest four hours at most will be lost. The other values can be studied with the software UIP5 and exported to a text file for further treatment in e.g. MS-EXCEL

Standard configuration:

Out(1) is carbon monoxide output, Out(2) is carbon dioxide output and Out(3) is relay output. Out(4) is error status OR Out(3) is open.

Out(1) = measuring signal for carbon monoxide concentration
 Out(2) = measuring signal for carbon dioxide concentration
 Out(3) = ON/OFF of demand of air quality. The relay is open in alarm situations and at power loss.
 NOTE! There is a two minutes delay after start-up.
 Out(4) = error status OR Out(3) open, carbon monoxide concentration > 35ppm AND carbon dioxide concentration > 1500ppm. There is a two minutes delay after start-up.

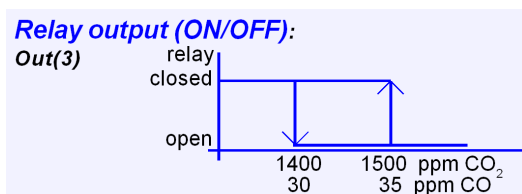



Figure 1. The control signal of air quality

Terminals and outputs description

The table below specifies cable connections of the aSENSE MIII.

Cable connections	Descriptions and ratings
Power supply	
1  +	Positive pole of DC power supply is connected to +~. Sensor performs half wave rectification of supplied AC voltage. Power supply lines are protected by varistor from voltage spikes and over voltage. A fuse and a diode protect the electronics. Nominal specification:24VDC, 24VAC ±20%,50–60Hz Absolute minimum to maximum ratings 16.5–40VDC
2 	Connected to sensor's ground. Negative pole connection for DC power supply The same ground reference has to be used for the aSENSE MIII unit and for the control system!
5 M	Signal ground protected by PTC fuse

Outputs for aSENSE MIII

3 Out(1)	Factory setting is 0–10VDC for 0–100ppm CO
4 Out(2)	Factory setting is linear output, 0–10VDC for 0–2000ppm CO ₂
6, 7 Out(3)	Isolated OFF/ON relay N.C. 1mA/5V up to 1A/50VAC/24VDC. ON < 30ppm CO AND < 1400ppm CO ₂ The green LED is lit OFF > 35ppm CO AND > 1500ppm CO ₂ The relay is open in alarm situations and at power loss. The red LED is lit and the green is not lit.
8 Out(4)	Open collector, error status with two minutes delay after start: Open: No error detected AND normal gas concentrations Closed: Error detected OR high gas concentrations The red LED is lit if an error OR high gas concentrations are detected. If an error is detected also the yellow LED is lit
9,10 DI	Digital Input 1, Closed contact current 1mA, Open contact voltage max 5V, Do not apply any voltage on this input!

Indicators

Green	ON normal operation OFF gas concentrations above normal
Yellow status LED	OFF = OK, Lit = Fault. Flashes when a successful push has been done in the push button menu.
Red status LED	Lit when the relay is closed
LCD	LCD is dedicated to represent measured values and status of the sensor.
Start point selection jumper	Jumper top position provides 0Vdc or 0mA start point for Out(1), Out(2) (0–20mA or 0–10V). Jumper bottom position provides 2VDC or 4mA start point for Out(1), Out(2) (4–20mA or 2–10V).
Communication selection jumper	MB = Modbus communication protocol SA = Senseair communication protocol

Out(1)	Jumper in left position gives mA output, 0/4–20mA. Jumper in right position gives V output, default, 0/2–10 V.
Out(2)	Jumper in left position gives mA output, 0/4–20mA. Jumper in right position gives V output, default, 0/2–10 V.
Out(4)	Jumper in left position gives open collector output, default Jumper in right position gives V output.
CALb CO2	Background calibration = CO₂ sensor calibration with fresh air. An easy way to correct the zero point error. The sensor needs fresh air (380–420ppm CO ₂). The CO ₂ sensor is calibrated to 400ppm CO ₂ .
CAL CO	Zero point calibration of the CO sensor with fresh air. The CO sensor is calibrated to 0ppm CO.

Serial Communication

UART (TxD, RxD)	<p>Available from JP3. 5V CMOS logical levels, Senseair communication protocol. Logical levels corresponds 5V powered logics.</p> <p>Protection 56R resistors are added on RxD and TxD lines RxD line is configured as digital input. Input high level is 2.1V min Input low level is 0.8V max TxD line is configured as digital output. Output high level is 4.0V Output low level is 0.75V max</p> <p>RxD input is pulled up to DVCC = 5V by 56kΩ TxD output is pulled up to DVCC = 5V by 56kΩ</p>
-----------------	--

Table 2. Cable connections of the aSENSE MIII

General PCB overview

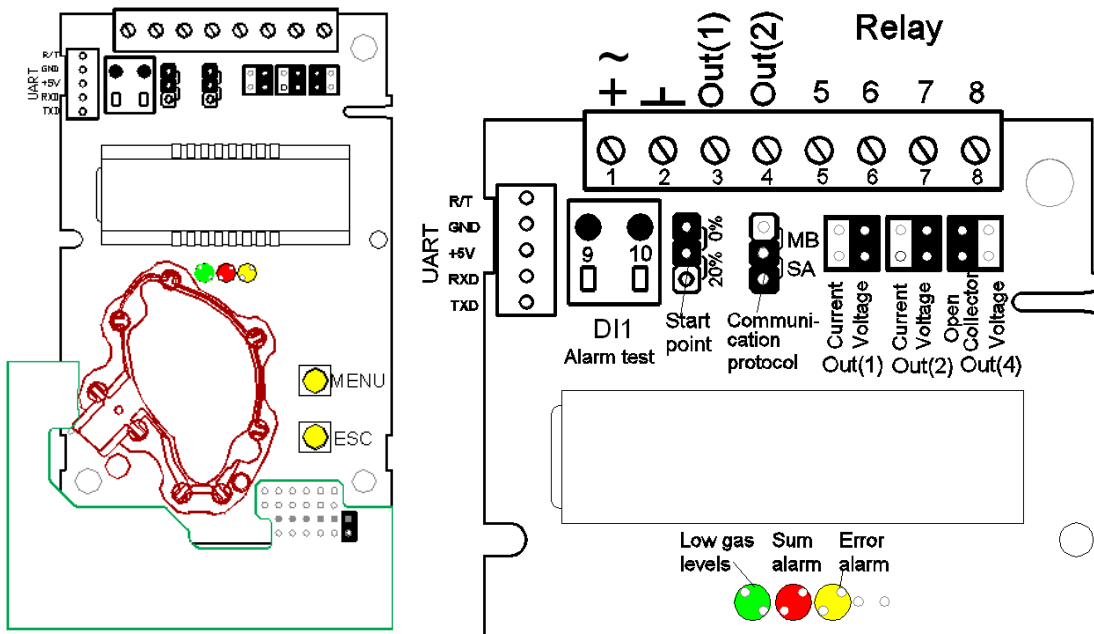

Figure 2. The aSENSE MIII PCB with jumpers and terminal area enlarged

Push button operation for aSENSE MIII

This sensor has two push buttons, MENU and ESC. The YELLOW LED will acknowledge a successful push by a short flash. The push button MENU is available for selection of display value or maintenance commands, whereas ESC is available to escape back from a selected level.

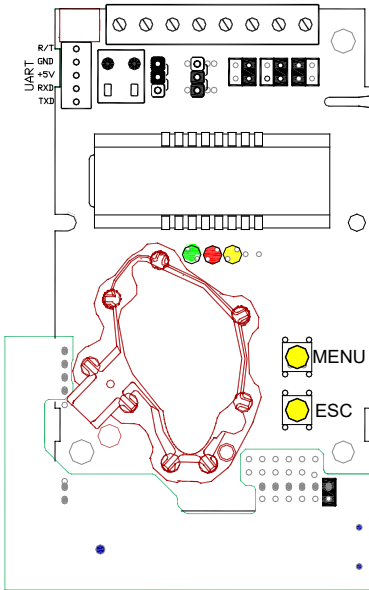

Figure 3. The sensor with push buttons

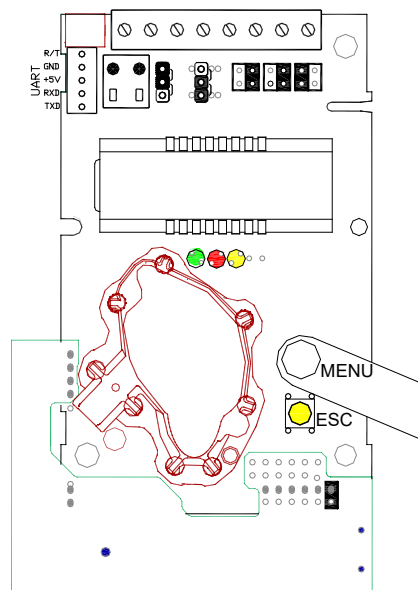

Figure 4. The push button MENU is pushed

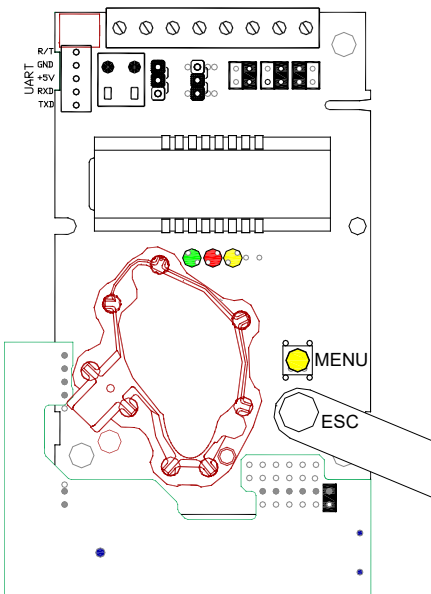

Figure 5. The push button ESC is pushed

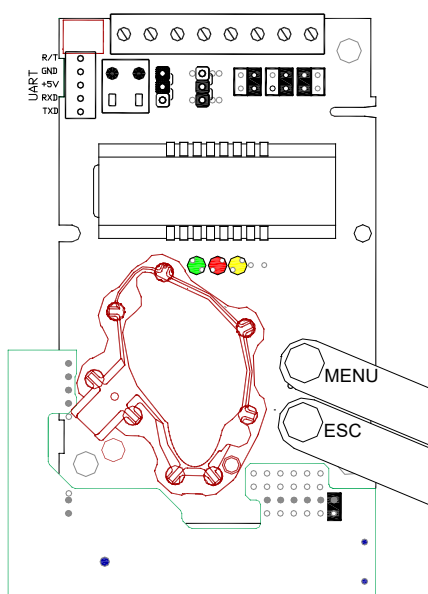

Figure 6. The ENTER command is done by pushing buttons MENU and ESC at the same time for about 14 seconds

Option - Network Adapter for Connection to RS-485-Network

The network adapter can be used to connect the Senseair sensor to a RS-485-network. The adapter is a small printed circuit board which can be used with all sensors with the housings large enough. The green LED flashes every time the adapter answers calls from the network master.

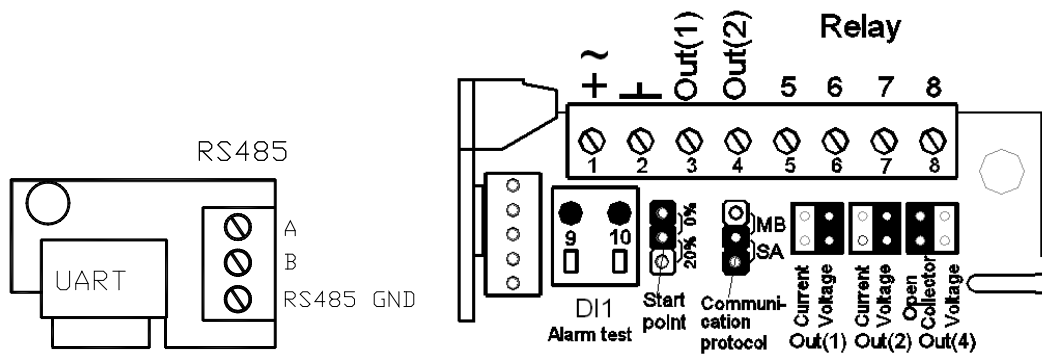

Figure7. The RS-485 adapter

The adapter should be mounted perpendicular to the main PCB. **The adapter should be put on the UART connector with all five pins connected.** All five pins of the UART must be connected. For aSENSE the adapter should be mounted with the RS-485 terminal facing the other terminals and the LED facing the display.

Display modes

In DISPLAY MODE the *DEFAULT* operation is that the sensor alternates between *temperature and carbon dioxide readings* presentation. The push button MENU(+) is used to select the indicated value on the display to be *the error code or the set points of temperature and CO₂*. The display will always return to the Default display mode after power up. If a *permanent change* of default values is requested the PC software is to be used.

Function Line	Display	Time limit	Function description
0	CO / CO ₂	no	DEFAULT - Normal operation
1	Exxx	yes	Error code. If no error has been detected the code E0 is shown. The error code is reset with Entr(+/-).
2	Present CO and CO ₂ set points	no	Toggle between display of CO and CO ₂ set point with MENU(+).

Table 3. On the display without entering the maintenance menu

Maintenance level

A number of execution options are available from the MAINTENANCE MENU (see Table IV). This level is accessed only from the display mode in the **set points of CO and CO₂** selection. A two buttons push and an access code restrict access, intended for competent trained service personnel only.

The Entr(+/-) command is done by PUSHING MENU AND ESC AT THE SAME TIME (hold down for about 14 seconds). The access code has eight binary digits; one press at MENU(+) equals 1 and one press at ESC(-) equals 0. The code value can be changed for your personal choice from the software UIP5. The menu diagram in detail is shown in the appendix.

Always use the ESC button to return to the DEFAULT mode. Several pushes of the ESC button may be needed to return to the DEFAULT mode. The **Entr(+/-)** push (MENU & ESC) eventually leads to execution of functions, which causes temporary or permanently change of any parameter, that affects the system outputs!

Function Line	Display	Time limit	Function description
3	ECxx	yes	Access code to the service menu The default value of the code is 255 (=11111111, that is eight presses on MENU(+)). Press down MENU(+) and let it scroll until it stops. The last two digits of the code are shown. Then ENTER to accept the selected code.
4a	SPCO	yes	For setting the temperature set point .
4b	The present CO set point	yes	For increase / decrease of the CO set point . The set point is increased by stepping with MENU(+) button. Decreasing is done by stepping with the ESC(-) button.
5a	SPc	yes	For setting the set point of the CO₂ concentration
5b	The present CO ₂ set point	yes	For increase / decrease of the CO₂-concentration set point The set point is increased by stepping with MENU(+) button. Decreasing is done by stepping with the ESC(-) button.
6a	AOUt	yes	First step of adjusting the analogue outputs MAX and MIN values
6b	An xx	no	Select analogue output by stepping with MENU(+) button.
6c1	SetL	no	Leads to adjustment of the MIN value.
6d1	The present MIN value in % of FS	no	Increase the MIN value by stepping with the MENU(+) button. Decrease by stepping with the ESC(-) button. The output is set to the MIN value and can be checked with a multimeter.
6e1	Sure	no	The adjustment is saved by pressing Entr(+). Press ESC to return without saving.
6c2	SetH	no	Leads to adjustment of the MAX value
6d2	The present MAX value in % of FS	no	Increase MAX value by stepping with the MENU(+) button. Decrease by stepping with the ESC(-) button. The output is set to the MAX value and can be checked with a multimeter.
6e2	Sure	no	The adjustment is saved by pressing Entr(+). Press ESC to return without saving.
7	CALb	yes	Background calibration = CO sensor and CO₂-sensor calibration with fresh air. An easy way to correct the zero point error. The sensor needs fresh air (380–420 ppm CO ₂). The calibration must be confirmed by pressing Entr(+).(+-). The CO ₂ sensor is calibrated to 400ppm CO ₂ and the CO sensor to 0ppm CO.
7a	Sure	yes	Confirm that a background calibration shall be done.
8	CAL	yes	Zero point calibration of the CO sensor and the CO ₂ sensor. The sensor needs zero gas. See the zero point calibration instruction. The calibration must be confirmed by pressing Entr(+).
8a	Sure	yes	Confirm that a zero point calibration shall be done.

Table 4. Maintenance functions available on aSENSE MIII to set output limits. Time limit refers to an internal time-out that returns the LCD and maintenance function back to normal. ENTER is a simultaneous pressing on MENU and ESC.

NOTE! If a power failure happens when the sensor has Out(1)...4 locked to min/max limits, then the sensor will have this output locked when the power returns. It is necessary to enter this menu item and release the output manually!

Calibration

If the measurement of a sensor is to be verified, a test gas with carefully determined concentration of CO and CO₂ must be used. For zero calibration pure nitrogen or air that has passed through a chemical absorber should be used. In fresh air the carbon monoxide concentration is nearly zero. The Zero calibration kit can be used to produce carbon dioxide free air. Check the CO and CO₂ values of the display or the voltage of the output 1 for CO and the voltage of the output 2 for CO₂ with a multimeter when the values have stabilised.

When a zero calibration shall be executed a plastic tube with 2.2 mm outer diameter and 0.8 mm inner diameter shall be inserted in marked holes of the sensor. Plastic tubing is connected to the tube. The gas flow should be between 0.3 and 1.0 l/min.

The yellow LED flashes when a calibration is executed .A calibration will only be executed if the gas concentration is stable. If the yellow LED does not flash after 8 seconds no calibration has been executed. Then try to do another calibration.

Marking	Function
CALb CO2	Background calibration = CO₂ sensor calibration with fresh air. An easy way to correct the zero point error. The sensor needs fresh air (380–420ppm CO ₂). The CO ₂ sensor is calibrated to 400ppm CO ₂ .
CAL CO	Zero point calibration of the CO sensor with fresh air. The CO sensor is calibrated to 0ppm CO

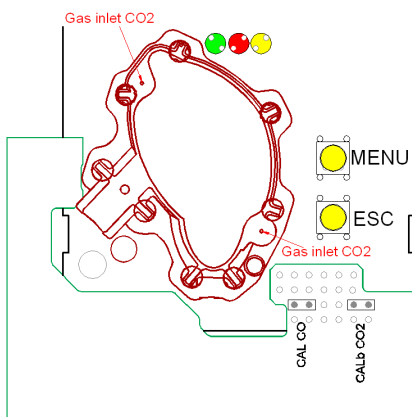

Figure8. Part of the PCB with holes for gas inlets marked

Self-diagnostics

The system contains complete self-diagnostic procedures. A full system test is executed automatically every time the power is turned on. For aSENSE MIII the internal voltage regulators and outputs are checked. In addition, constantly during operation, the sensor probes are checked against failure by checking the valid dynamic measurement ranges. All EEPROM updates, initiated by the sensor itself, as well as by external connections, are checked by subsequent memory read back and data comparisons. These different system checks return error bytes to the system RAM. The error codes are available by connecting a PC with a special RS232 cable connected to the UART port slide connector. The error codes are shown in the software UIP (version 4.3 or higher). *Warm up* and *Out of Range* are the only bits that are reset automatically after return to normal state. All other error bits have to be reset manually after return to normal state – either by pushing MENU & ESC buttons simultaneously for =Entr(+/-) or by power off and restart.

By pushing the push button "MENU" the error code *number Exxx* is shown on the LCD. Descriptions of the different codes are listed below.

The yellow LED flashes if an error has been detected. If a fatal error has been detected the yellow LED is lit.

Error code and action plan

Bit #	Error code	Error description	Suggested action
0	N/A	Fatal Error	Try to restart sensor by power OFF/ON. Contact local distributor
1	2	Reserved	-
2	4	Algorithm Error. Indicate wrong EEPROM configuration.	Try to restart sensor by power OFF/ON. Check detailed settings and configuration with UIP software version 4.3 or higher. Contact local distributor.
3	8	Output Error Detected errors during output signals calculation and generation.	Check connections and loads of outputs. Check detailed status of outputs with UIP software version 4.3 or higher.
4	16	Self-Diagnostic Error. Algorithm timeout	Check detailed self-diagnostic status with UIP software version 4.3 or higher. Contact local distributor
5	32	Out of Range Error Accompanies most of other errors. Resets automatically after source of error disappearance.	Try sensor in fresh air. Check connections of temperature and relative humidity probe. Check detailed status of measurements with UIP software version 4.3 or higher. <i>See Note 1!</i>
6	64	Memory Error Non-fatal error during memory operations.	Check detailed settings and configuration with UIP software version 4.3 or higher.
7	128	Warm Up state Is always set after power up or power failure. Resets after restart sequence.	If it doesn't disappear in half a minute, check power stability.

Table 5 Error codes

Note 1. Any probe is out of range. It occurs, for instance, during over exposure of CO₂ sensor, in which case the error code will automatically reset when the measurement values return to normal. It could also indicate the need of zero-point calibration. If the CO₂ readings are normal, and still the error code remains, the temperature sensor can be defect or the connections to it are broken.

Remark: If several errors are detected at the same time the different error code numbers will be added together into one single error code!

NOTE! The sensor accuracy is defined at continuous operation (at least three (3) ABC periods after installation)