

# Installation Manual

## aSENSE Duct

CO<sub>2</sub> / temperature sensor for mounting in ventilation ducts

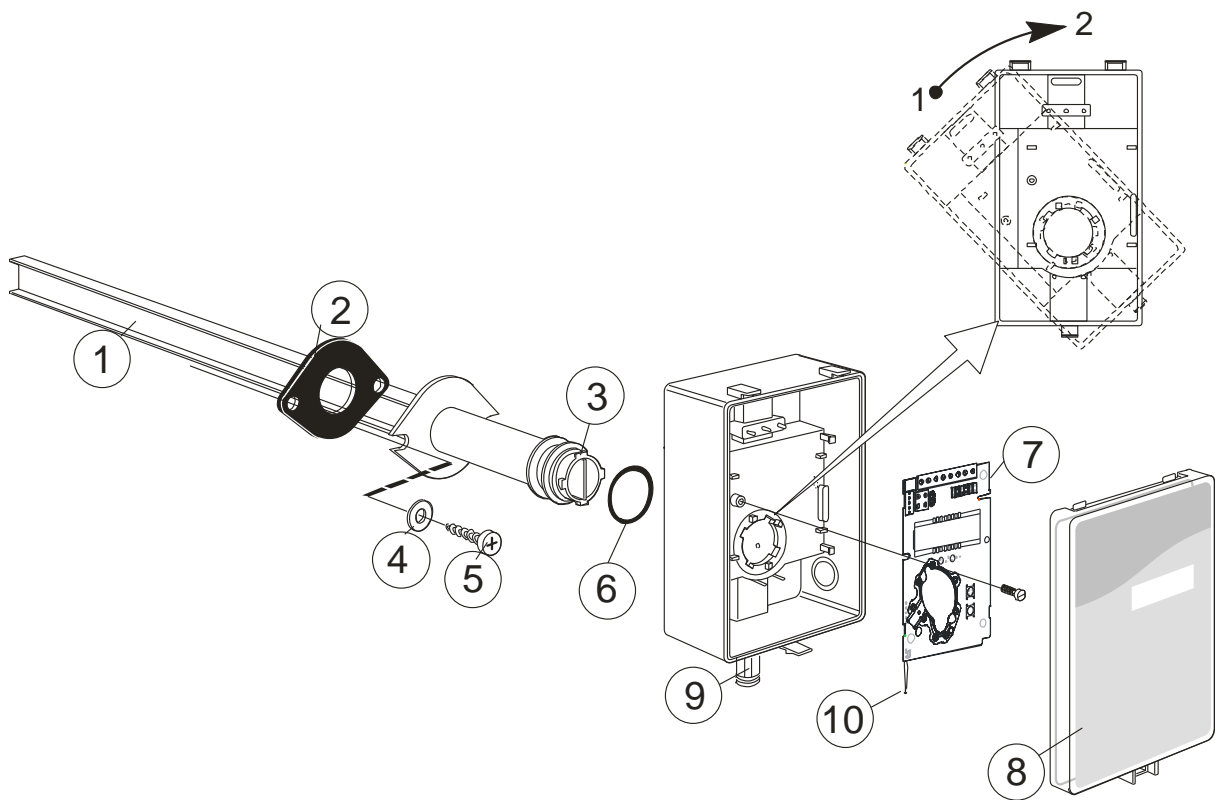

- 1 Sampling probe
- 2 Sealing gasket
- 3 Largest locking nob
- 4 2 washers (Not included)
- 5 2 screws (Not included)

- 6 O-ring 29,2x3,53 (Factory supplied mounted in box)
- 7 PCB (Factory supplied mounted in box)
- 8 Snap-in lid
- 9 PG9 cable entry bushing
- 10 Temperature sensor (to be put into the sampling tube)

**Senseair**

an Asahi Kasei company

Mounting of aSENSE on to the duct.

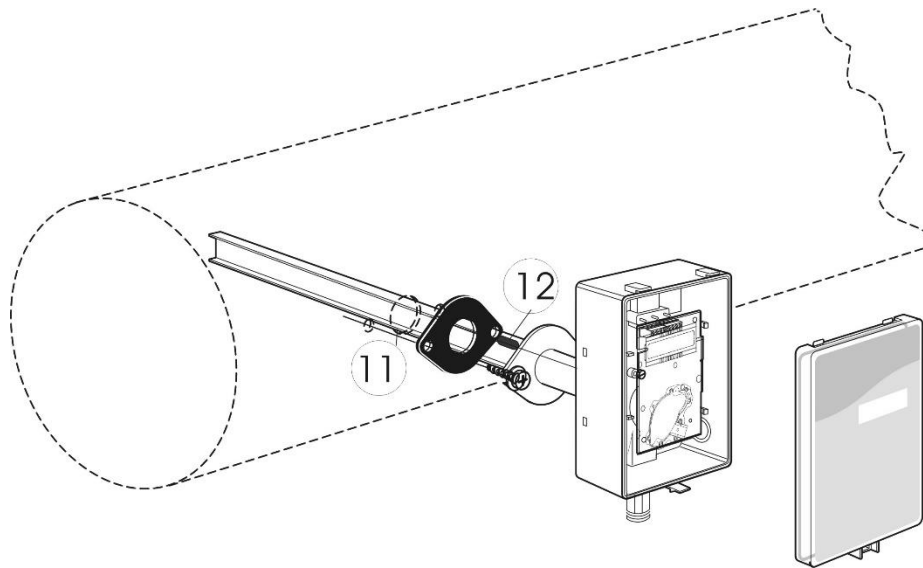

- 11 Hole with 25 mm diameter
- 12 Temperature sensor with 110 mm cable mounted in the sampling probe

## Mounting Instruction

Since there might be a substantial pressure difference in duct mounting applications, it is essential to avoid ambient air from suction into the duct mounting box. For correct function it is indispensable that the sealing of the box cover, the cable entry bushings, the cable feed through and the duct entrance are absolutely tight. The duct entrance may need extra sealing paste in order to prevent leakage. The PCB must be handled carefully and protected from electrostatic discharge.



- 1) **Electrical cable entry:** The box has a factory mounted cable entry bushing in dimension PG9. Never feed more than one cable through each cable entry bushing, or else gas might leak through!
- 2) **Mounting the tube:** Drill a hole (10) with 25 mm diameter (or 1 inch) for the sampling probe and two holes with 4 mm diameter for the screws (5) into the air duct and mount the tube (1) with the gasket (2). The sampling probe should be mounted with the largest locking knob on top. The unit can be mounted with the air coming from the left or right.
- 3) Attaching the sensor box is made to the sampling probe by a snap-in bayonet fitting. First, carefully stick the temperature probe (11) into the sampling probe. (1). Orient the box onto the sampling probe so that the box upside is on the same side as the largest locking knob (3). When the probe is fitted into the notches of the box, then turn the box clockwise until stop (see Figure 1). Position 1 indicates *open* where the box can be removed from the sampling probe. In position 2 the box is locked to the probe.



If, for some reason, the PCB must be removed, care must be taken to protect from electrostatic discharge! Normally, removing the PCB is NOT required.

■ ■ ■ ■  
**Senseair**



## Electrical connections

The power supply has to be connected to  and .  is considered as system ground. If the analogue output is connected to a controller the same ground reference has to be used for the aSENSE Duct unit and for the control system! Unless different transformers are used, special precautions need to be taken.

The aSENSE Duct signal and power supply grounds are common.

The same ground reference has to be used for the aSENSE Duct unit and for the control system!

Connect the power after mounting. The analogue output should be connected before measuring.

Connection Terminal	Function	Electrical Data	Remarks
 	Power (+)	24 V AC/DC+ (+-20%), 1W	See note 1.
	Power ground (-)	24 V AC/DC-	
Out(1) CO <sub>2</sub>	Analogue Output 1 (+) Standard 0 – 2000 ppm	0 - 10 VDC or 0 - 20 mA, 2 - 10 VDC or 4 - 20 mA or According to label	According to positions of Out(1) and start point jumpers. See note 2.
Out(2) Temp	Analogue Output 2 (+) Standard 0 - 50 °C or 32 - 122 °F	Same as Output 1	According to positions of Out(2) and start point jumpers. See note 2.

Note 1: The ground terminal is used as negative power supply DC input or AC phase ground  (halfwave rectifier). A single transformer may be used for the entire system.

Note 2: aSENSE Duct can deliver a voltage or a current loop for Out(1) / Out(2). To change between voltage and current output mode the hardware jumpers are used. There is one jumper for Out(1) and one for Out(2), so that one output can be a voltage output and the other a current output. Both, voltage output and current outputs, can have start points 0% (0 - 10 V DC or 0 – 20 mA) or 20% (2 - 10 V DC or 4 - 20 mA). The same start point is used for both outputs. See the user manual.

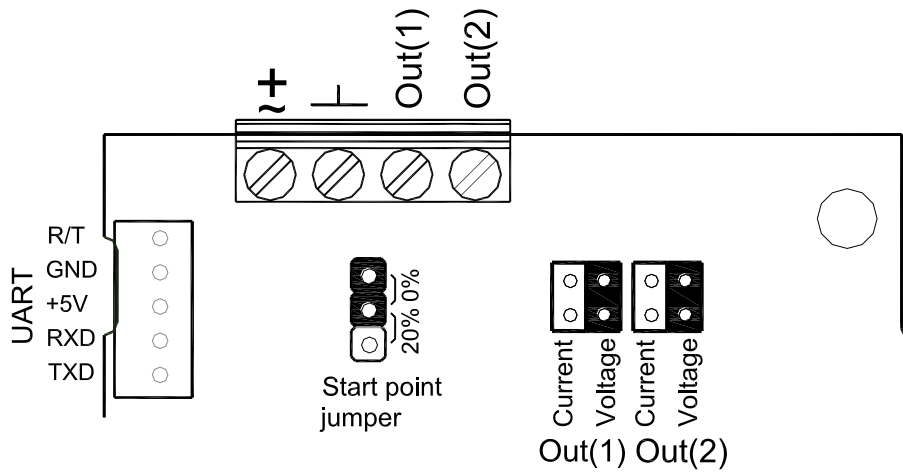

Terminals and jumpers on aSENSE. The darker positions are default settings.

## Dimensions

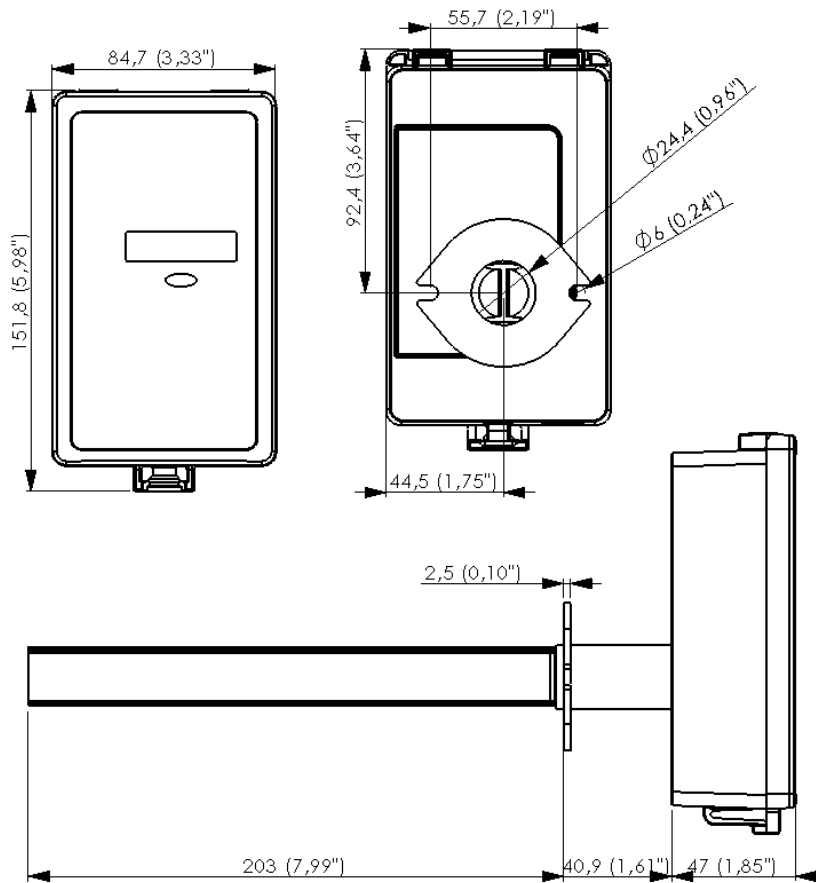

Dimensions of sensor in mm and (inches)